



Fixing Instructions

Trench Heating



Please unpack your delivery carefully and inspect the radiator and contents – any damages or shortages must be notified to your supplier **within 3 days of delivery** of your goods.

Specifications

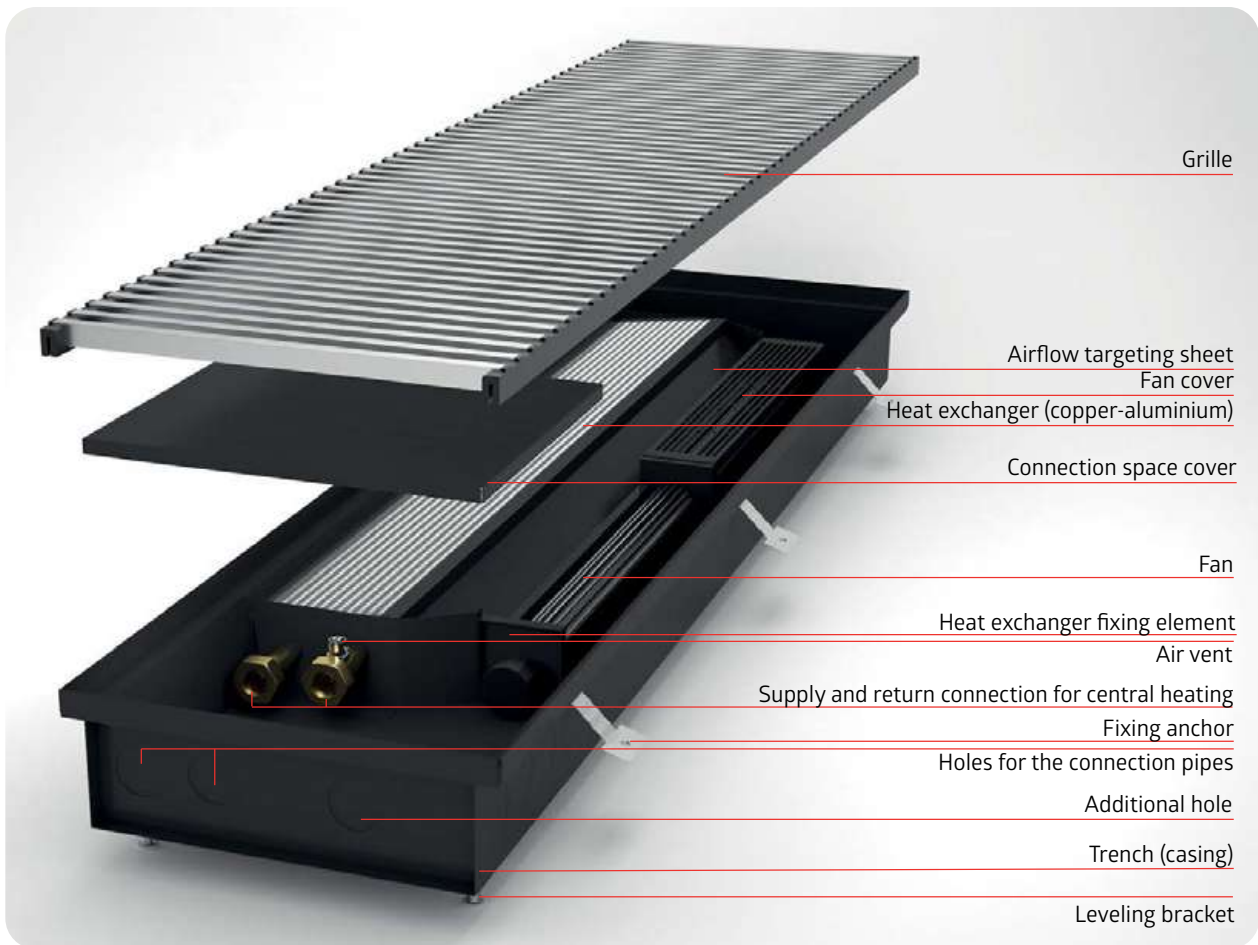

PLEASE NOTE: That in accordance with Part L1 2006 of the Building Regulations and BS7593:1992 code of practice for the treatment of hot water and central heating systems, we recommend flushing the heating system before installation of new radiators and then adding the correct quantity and type of inhibitor for use with the radiator and system to prevent corrosion. Damage caused to systems not protected by a suitable inhibitor will not be covered by the manufacturer warranty. It is the responsibility of the installer to ensure the correct use and suitability of the fixings provided. No liability for costs or damages arising from failure to do so can be accepted.

Installation Instructions

A

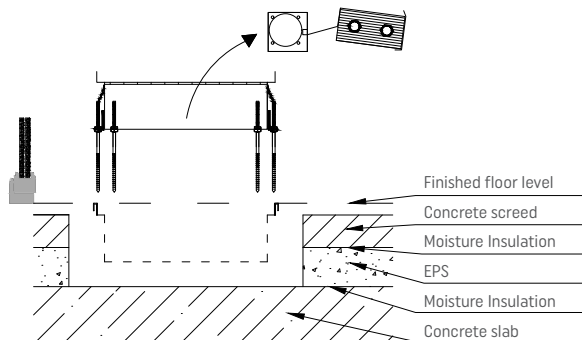

Prepare a hole that should be larger than the heater dimensions by about 40-50 mm on each side.

Thermal insulation layer around the trench heater should have thickness of at least 20 mm.

Depth of a hole should be planned so that the heater grate faced the floor finishing level.



NOTE: Prior to beginning of the assembly works, the heating set should be removed from the heater trench and secured. The set contains a fan, an injector and a heat exchanger. After taking these elements out, in the heater trench, re-install installation struts (factory attached to heaters).

B

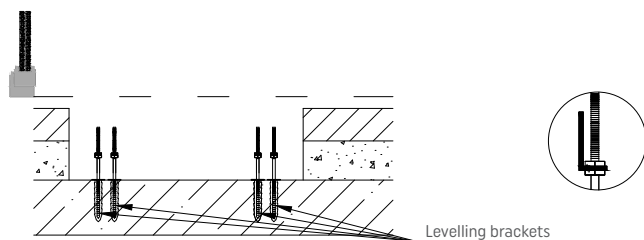

In the structural layer (e.g. concrete slab), prepare appropriate holes for levelling brackets - Screw M8 + rawlplugs. After hammering rawlplugs, screw the screws in them.

External anchors with levelling brackets are present only in the case of TURBO VKN5 heaters with the length of 235 cm or more.

In the trench, strike assembly holes - 2 installation holes and a 1 auxiliary hole (dedicated for cabling).

Strike with a light hammer on the points marked on the heater trench.

Striking is possible both from the „face“ and the side of the trench.

C

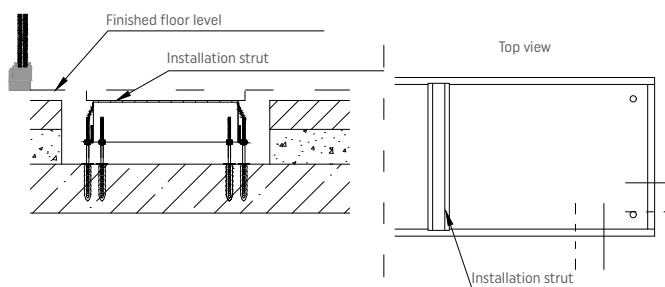

The trench is set and levelled on the previously mounted brackets. At this stage of works, the trench must be equipped with the factory attached installation struts.

Standard range of adjustment of levelling brackets is 35 mm.

Lead central heating installation ducts to the ducts along with cabling - motor and servomotor control and power supply of motors (24VDC).

Details concerning the electric connection can be found in separate diagrams.

Installation Instructions

D

The trench should be protected by means of an installation cover, and then by means of a dispenser with adjustable outflow, make thermal insulation made of low-expandable foam.

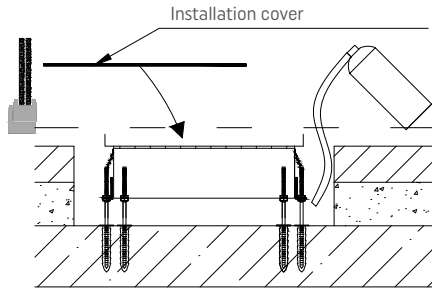

Take care of accurate filling of space between the trench and the floor layers.

In the case of installation of the heater in the floor on the ground, in the space between the thermal insulation with the screed and a heater there should be anti-damp insulation.



NOTE: The height of the foam should not be greater than 20 mm. In the event of necessity to make insulation in the duct with a greater depth it is recommended to make insulation of styrodur boards. In this case the low-expandable foam is used for filling other empty spaces between the floor layers, insulation boards and the tub of the heater.

E

Make screed, on which the trench edge will be based.

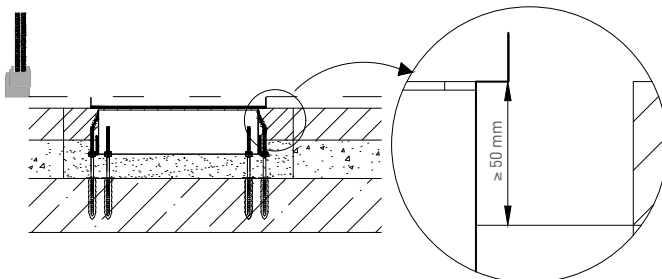

NOTE: The screed on which the trench edge will be based should have the height of at least 50 mm, which should be considered at stage of planning thermal insulation thickness.

The trench must be equipped with the factory attached installation struts. The trench should be secured with an installation cover.

F

When the screed sets, it is possible to safely remove struts and covers. After these activities, insert the heating set and screw it to the trench.

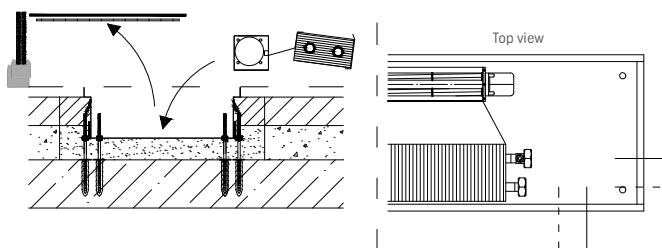

In the TURBO VKN5 heater, the fan should be placed on the side of the glazed bulkhead.

Installation Instructions

G

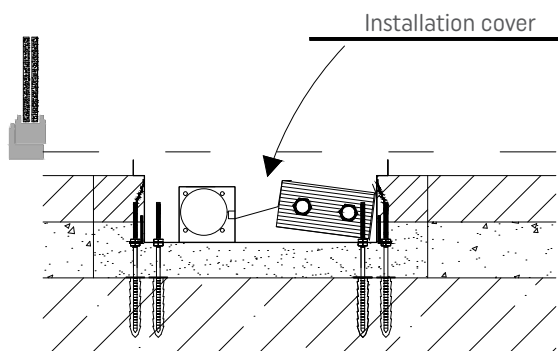

After fitting the heating set make hydraulic and electric connections.

After the completion of works the heater should be covered with an installation cover.

The central heating installation duct should be connected to the stub pipe equipped with a vent. Electric connection should be made according to separate diagrams.

H

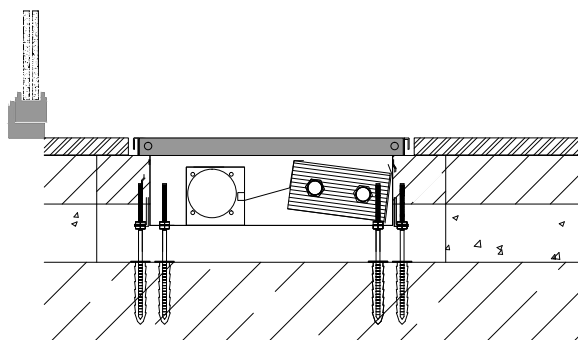

When conducting finishing works, the heater should remain protected by an installation cover.

After the completion of finishing works, install the framing and the grate on the heater.



NOTE: Grates, framing, thermostatic and cut-off valves thermostatic heads, servomotors, regulators, power supply units and installation board are elements of additional equipment of the heater.

Electrical Wiring Diagrams

Electrical wiring diagram - RDG 160T

DIP switches of the RDG160T controller should be set in accordance with the diagram shown in the figure.

Programming the RDG160T controller

Press both (left and right) buttons of the controller for at least 3 seconds. Then release both buttons and again, for over 3 seconds, press only the left button, then turn the controller knob at least half-turn counterclockwise. The display will show the parameter symbol, e.g. P12, which means entering the servicing parameter settings mode. The demanded parameter is selected by turning the knob. After selecting the relevant parameter, its settings can be changed. Press the right button (enter). The digit or the size on the display under the line with a given parameter will start flashing. Change in the setting consists in rotating the knob until obtaining the required amount, e.g. factory setting P52 = 1, after change P52 = 2. After completion of the setting, again press the right button to approve selection. The same applies to other parameters which require changes in respect of factory settings. After the end of settings press the left button (exit).

List of settings

Configuration of parameters:

P01=0	P46=1	P38=0
P40=0	P42=0	P52=2
P60=89	P61=359	

The above settings provide periodical start-up of the fan despite achieving the desired temperature in the room: it will turn on every 89 min. for 2 min., and in the economical mode, every 359 min. for 2 min.

In the case of installation of more heaters, pay attention to even load of output terminals of 24 VDC power supply unit.

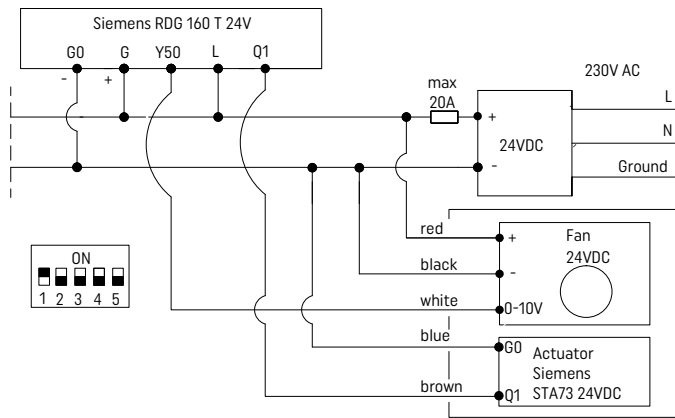

Electrical wiring diagram - VER-24



NOTE: TURBO VKN5 heater fans should be supplied with 24 VDC current. IT IS FORBIDDEN to supply them with network voltage of 230 V AC.



NOTE: All assembly works should be carried out in accordance with valid construction standards and the OHS regulations by qualified employees from the construction, sanitary and electrical industry. Responsibility for any possible damage resulting from incorrect installation of devices shall be borne by the user of the device.

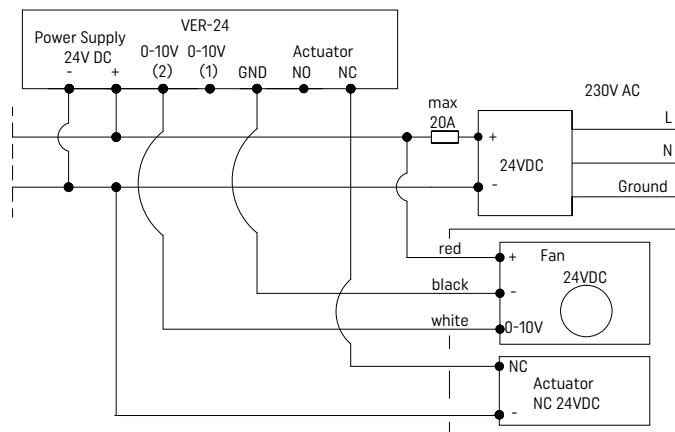

User's Manual VER-24



I.	Safety	3
II.	Device description.....	4
III.	Installing the controller.....	4
IV.	Operating the controller.....	7
	IVa) Principle of operation.....	7
	IVb) Description of main screen.....	7
	IVb) Controller operation modes.....	8
V.	Controller functions – main menu options	9
	V.a) Selecting the profile.....	10
	V.b) Temperatures settings	12
	V.c) Time settings	12
	V.d) Schedule settings.....	13
	V.e) Screen settings	13
	V.f) Alarm clock settings.....	13
	V.g) Controller settings.....	14
	V.h) Protections	15
	V.i) Language selection.....	15
	V.j) Information about software	15
	V.k) Stand-by mode	16
	V.l) Service settings	16
VI.	Controller functions – service menu options	16
	VI.a) Temperature settings	17
	VI.b) Selecting the system.....	17
	VI.c) Selecting the mode	17
	VI.d) Output configuration	18
	VI.e) Fan advanced settings	19
VII.	Alarms	20

I. Safety

Before using the device for the first time the user should read the following regulations carefully. Not obeying the rules included in this manual may lead to personal injuries and device damage. The user's manual should be stored in a safe place for further reference.

In order to avoid accidents and errors it should be ensured that every person using the device has familiarized themselves with the principle of operation as well as security functions of the device. If the device is to be sold or put in a different place, make sure that the user's manual is there with the device so that any potential user has access to essential information about the device. The manufacturer does not accept responsibility for any injuries or damage resulting from negligence; therefore, users are obliged to take the necessary safety measures listed in this manual to protect their lives and property.



WARNING

- The device should be installed by a qualified electrician.
- The regulator should not be operated by children.



NOTE

- Any other use than specified by the manufacturer is forbidden.
- The technical condition of cables should be checked regularly. The user should also check if the controller is properly mounted and clean it if dusty or dirty.

II. Device description

The application of the VER-24 regulator ensures convenient control over the Verano fan coil.

The VER-24 regulator has the following functions:

- Controlling the room temperature
- Smooth adjustment of the fan's revolutions
- Smooth adjustment of the valve's opening degree
- Controlling the valve ON/OFF
- Daily schedule
- Alarm clock
- Parental lock

The controller's equipment:

- a large, legible, color touch screen
- a built-in room sensor

III. Installing the controller

The controller should be installed by a qualified person.



WARNING

Risk of fatal electric shock from touching live connections. Before working on the regulator, switch off the power supply and prevent it from being switched on again.

The VER-24 regulator may be installed as a panel mountable on a wall.

First, the user should mount the rear installation cover to the wall where the room regulator will be connected in the electrical junction box. Then, the user should connect the power supply cables.

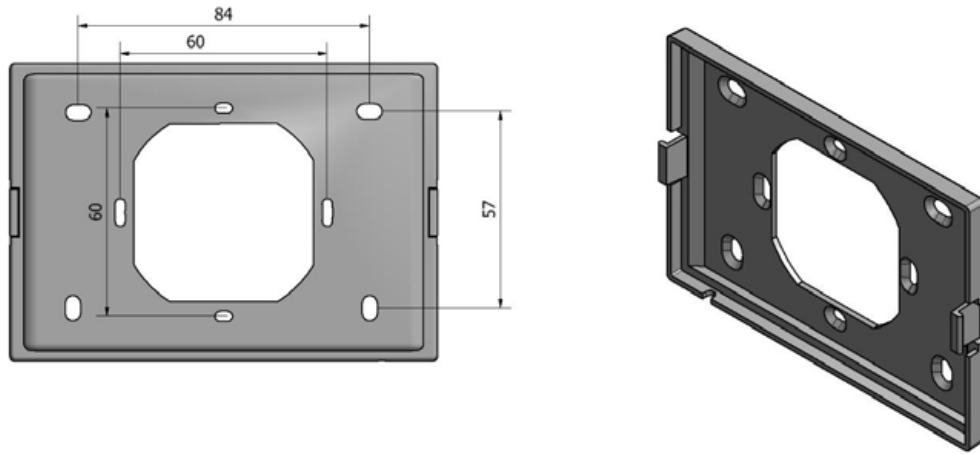

The room regulator should be installed on catches

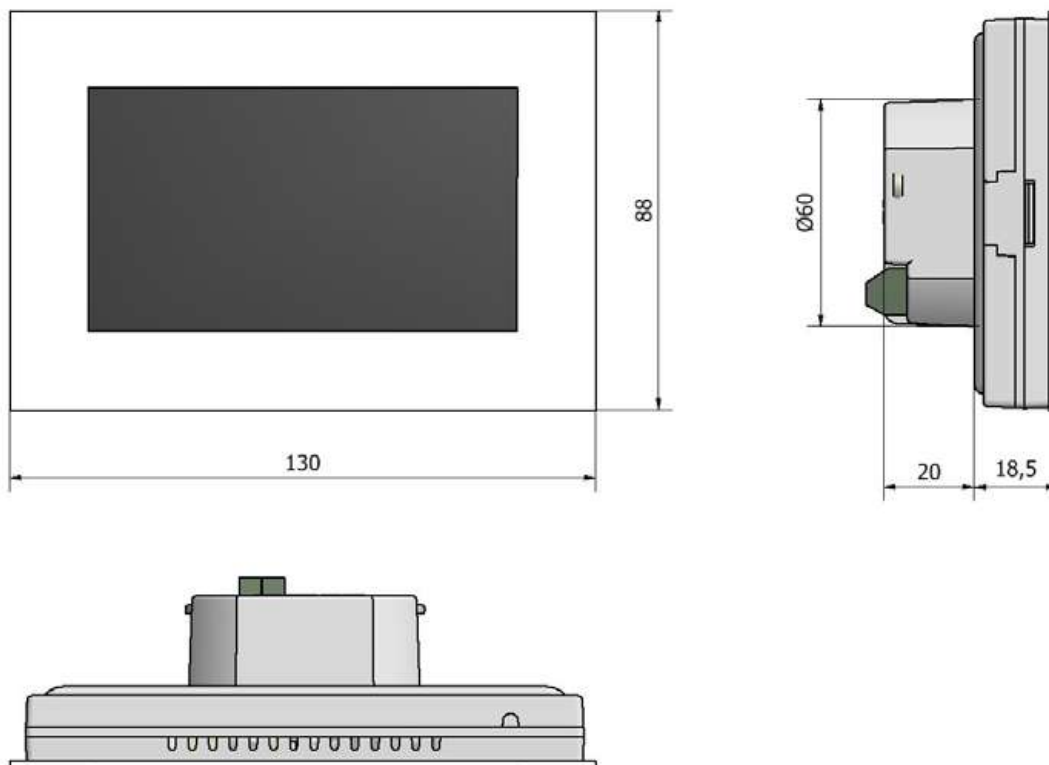

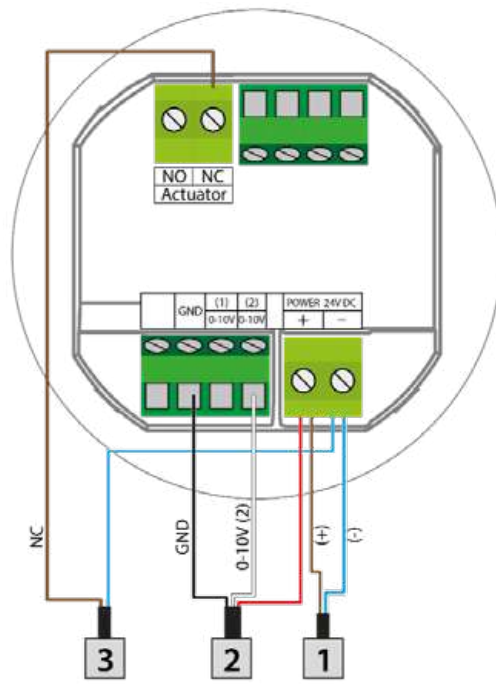

- 1** POWER 24V
- 2** SIGNAL CONTROLLED FAN 0-10V
- 3** ACTUATOR NC

CONNECTION SCHEME

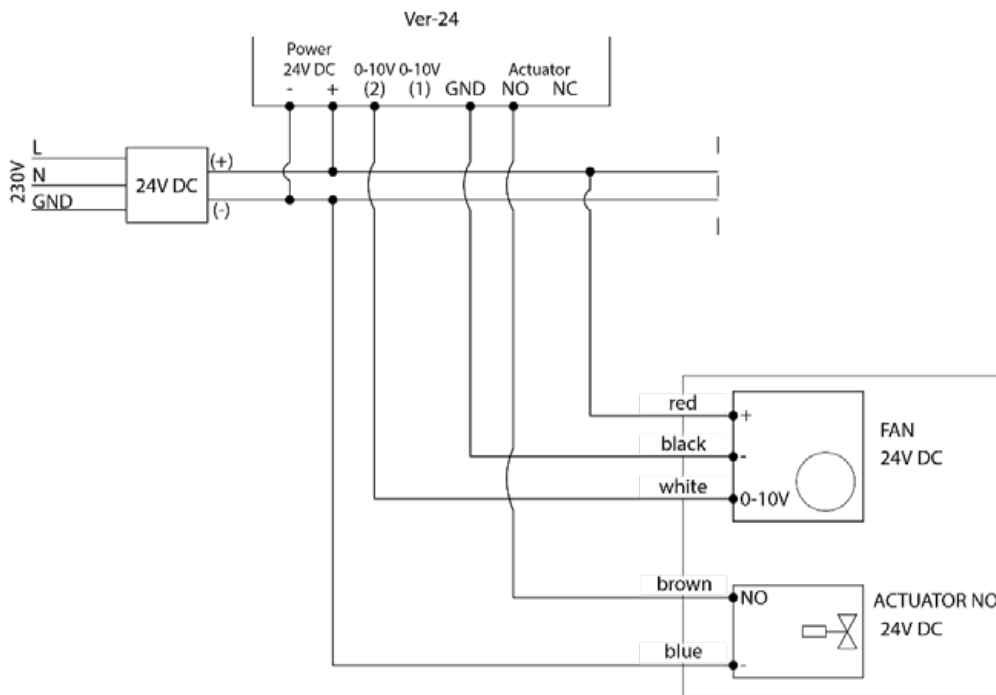

BLOCK CONNECTION SCHEME

IV. Operating the controller

IVa) Principle of operation

The VER-24 regulator controls the fan as well as the valves in order to maintain the set temperature in the room. Depending on the selected mode, it increases the temperature in the room (heating mode) or decreases it (cooling mode). The controller smoothly controls the fan's operation (depending on the need, it gradually increases or decreases its revolutions) and the valve's operation (depending on the need, it gradually increases or decreases the degree of its opening). Additionally, the controller may adjust the operation of the second valve – opening or closing it, depending on the need.

IVb) Description of main screen

The controller is equipped with a large graphic display with a touch panel. The main screen displays the current status of the controller's basic parameters.

Description of the main screen:

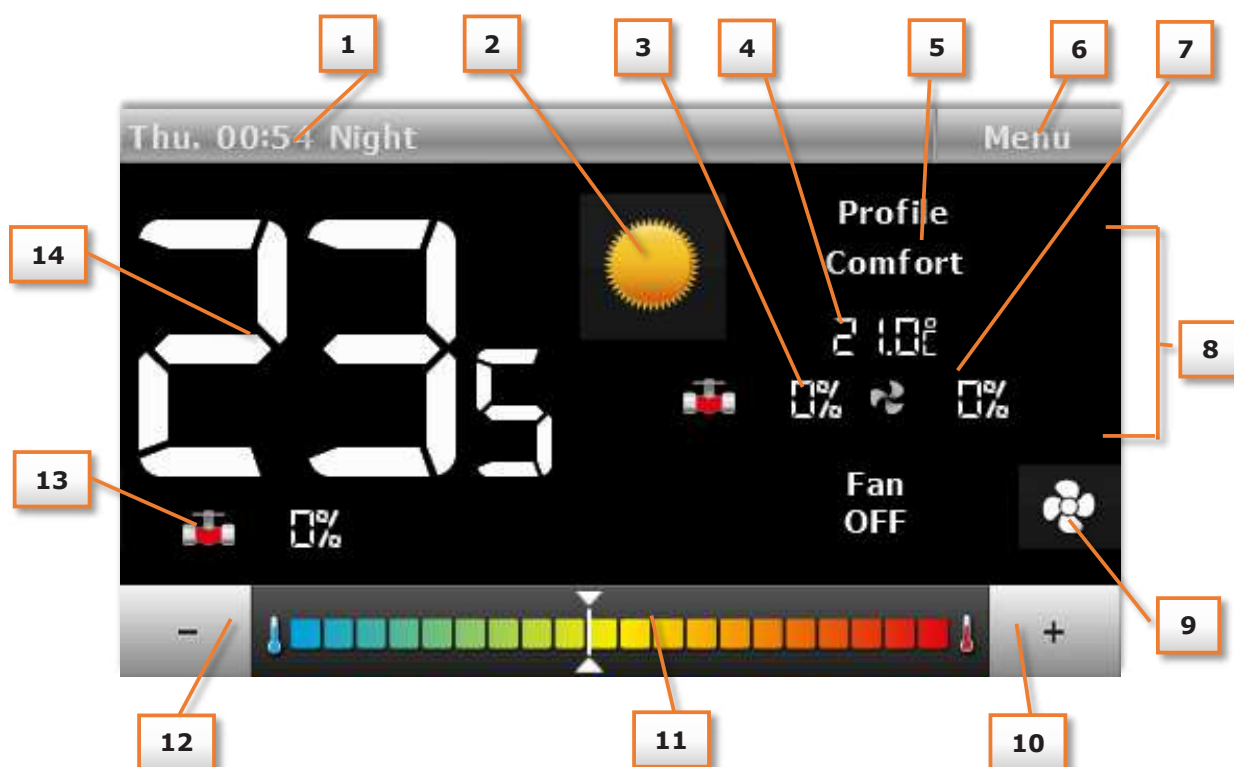

1. Information on the day of the week, hour and time of day
2. Icon for changing the operation mode:
 - Heating – Sun icon
 - Cooling – Snowflake icon

CAUTION



Function active when the option **Manual heating /cooling** is marked in the submenu **Mode selection** in the service menu. When another mode is selected, the icon for changing the operation mode is invisible and an icon informing on the enabled active mode appears in the top right-hand corner.

3. Degree of valve opening with smooth adjustment.
4. Valid set temperature (depending on the selected profile and operation mode).

5. Information on the controller's active operation profile.
6. Entering the controller's main menu.
7. Fan revolution speed
8. Icons informing on the current fan speed:
 - all three icons displayed – the fan operates with full speed
 - two icons displayed – the fan operates with medium speed
 - one icon displayed – the fan operates with minimum speed
 - no icon – fan does not operate
9. Icon for changing the fan's operation mode. The fan may operate in the following modes:
 - automatic – the fan's speed is adjusted by the controller's operation algorithm
 - manual – three speeds
 - disabled



CAUTION

Information on the current fan operation mode is saved in the controller's memory after 6 seconds from the last change of parameter.

10. Button used for increasing the set temperature – option active only in the profile Comfort. The set temperature changed in this place is valid only until the user enters the controller's menu or an automatic change of the operation profile (e.g. according to the schedule settings).
11. Strip for changing the set temperature settings – option active only in the profile Comfort. The set temperature changed in this place is valid only until the user enters the controller's menu or an automatic change of the operation profile (e.g. according to the schedule settings).
12. Button used for reducing the set temperature – option active only in the profile Comfort. The set temperature changed in this place is valid only until the user enters the controller's menu or an automatic change of the operation profile (e.g. according to the schedule settings).
13. Valve icon
 - red – valve configured as heating,
 - blue – valve configured as cooling
 - crossed out valve icon – valve disabled
14. Current room temperature.

IVb) Controller operation modes

The controller may operate in two modes, regardless of the selected profile: heating or cooling. The user selects the possibility to adjust particular modes in the submenu **Service menu / Mode selection**. It is possible to adjust only one valid operation mode – marking the option **Heating** or **Cooling**, or allow the manual switching of modes from the main screen position – marking the option **Manual heating / cooling**

Operation mode Heating

After the user selects this mode, the controller activates the fan and opens the valves in order to increase the temperature when it detects that the temperature in the room is lower than the set temperature (setting in the submenu **Temperature settings**). After the room temperature is increased to the set value reduced by the value determined by the user (setting in the service menu in the submenu **Temperature settings**), the controller switches into gradual reduction of the fan's revolutions and closing the valve.

After the set temperature is reached in the room, the fan is disabled and the valves are closed (the fan's automatic mode is enabled).

Operation mode Cooling

After the user selects this mode, the controller activates the fan and opens the valves in order to reduce the temperature when it detects that the temperature in the room is higher than the set temperature (setting in the submenu **Temperature settings**). After the temperature in the room is decreased to the set value increased by the value determined by the user (setting in the service menu in the submenu **Temperature settings**), the controller switches into gradual reduction of the fan's revolutions and closing the valve.

After the set temperature is reached in the room, the fan is disabled and the valves are closed (the fan's automatic mode is enabled).

V. Controller functions – main menu options

During the regulator's normal operation **the graphic display** displays *the main screen*.. After the user presses the menu button, it is possible to edit the controller's functions.

Due to the controller's complexity (great number of parameters to be edited), the menu was divided into the main menu and the service menu – protected with a four-digit code. The main menu contains the controller's basic operation parameters, e.g. mode selection, settings of set temperatures, appearance of the main screen etc.

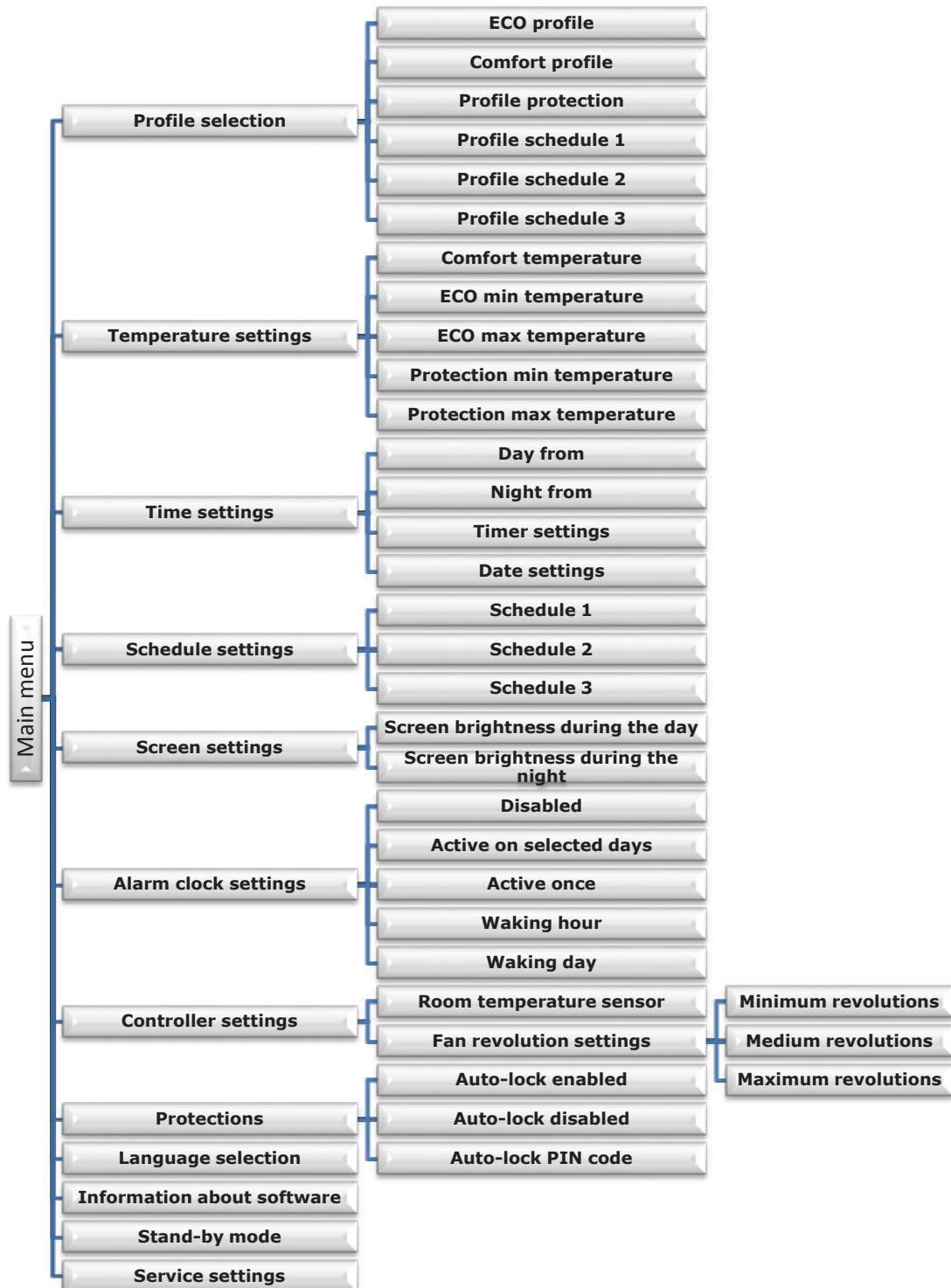

V.a) Selecting the profile

The parameters in this submenu are used to select the controller's operation profile.

Profiles available in the controller are used to maintain the temperature in the room at the set level. The user may select 3 various profiles (comfort, eco, protection) as well as three different schedules (1, 2, 3).



COMFORT:

In this profile, the user adjusts one set temperature (T_{zad}), Fig. 1, 2. If the temperature in the room decreases (**heating mode**) or increases (**cooling mode**) by $0.1\text{ }^{\circ}\text{C}$, the controller will gradually begin to open the valve and will activate the fan. When the temperature in the room is still decreasing (**heating mode**) or increasing (**cooling mode**), the controller will gradually open the valve. The valve will be completely open below the temperature $T_{zad} - \Delta$ (or above $T_{zad} + \Delta$). Fig. 2 presents the fan's operation.

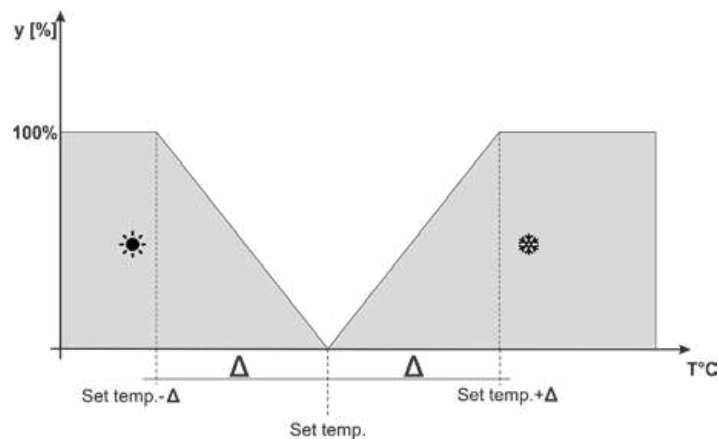

Δ - Delta comfort temperature
y - Valve operation

Figure 1 Chart of valve operation in the profile Comfort

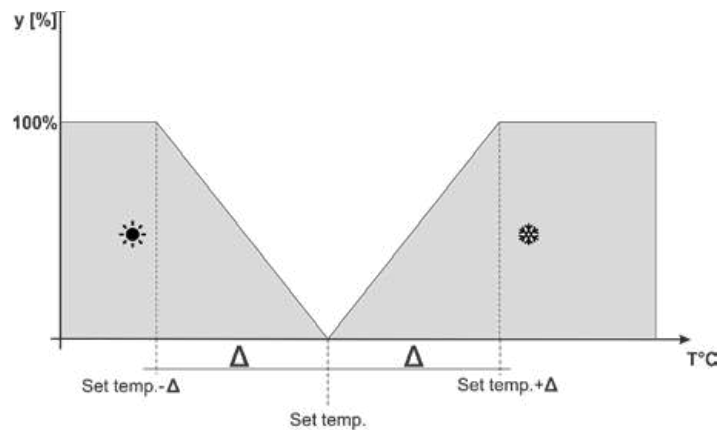

Δ - Delta comfort temperature
y - Fan operation

Figure No 2 Chart of fan operation in the profile Comfort

ECO, PROTECTION:

The profile PROTECTION operates similarly to the ECO profile. The only difference are the default values of set temperatures settings:

Minimum temperature PROTECTION < minimum temperature ECO

Maximum temperature PROTECTION > Maximum temperature ECO

The profile PROTECTION is used to maintain optimum values in the room protecting the system against freezing or overheating.

In this profile, the user adjusts two temperatures (T_{zad_min} , T_{zad_max}), Fig. 3.4. If the temperature in the room decreases (**heating mode**) below the temperature T_{zad_min} by $0.1\text{ }^{\circ}\text{C}$, the controller will update the valve's and the fan's settings (according to the settings) in order to achieve the set temperature in the room. If the temperature increases (**cooling mode**), the adjustment takes place similarly to the previous case.

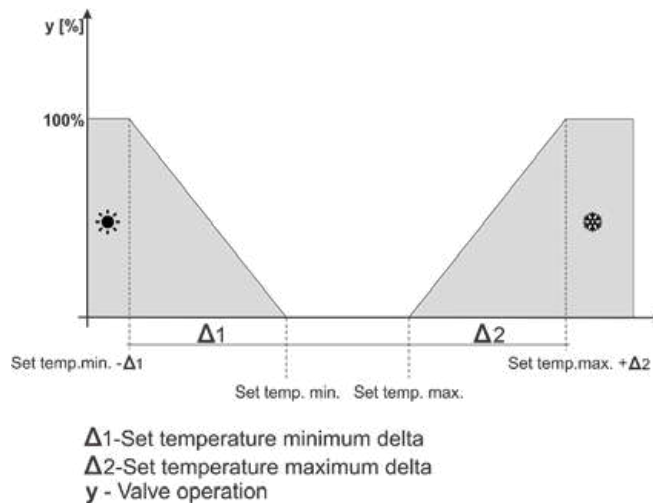

Figure No 3 Chart of valve operation in the profile ECO, PROTECTION

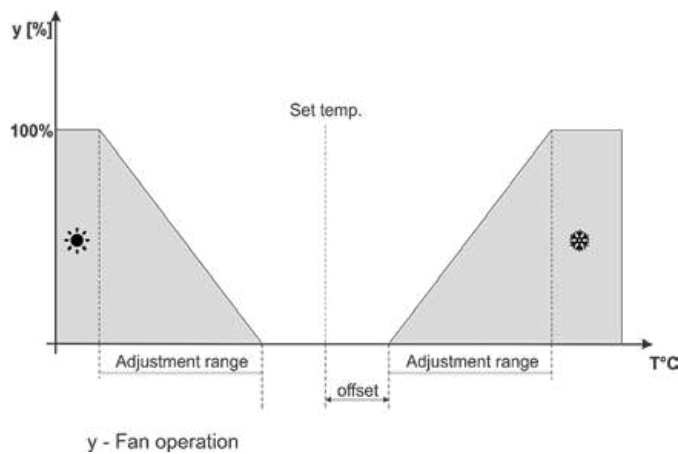

Figure No 4 Chart of fan operation in the profile ECO, PROTECTION

- **Profile schedule 1, 2, 3**

Enabling one of the three schedules will cause the controller to operate according to the previously defined program – the parameter **Schedule settings**

The schedules allows the user to adjust the requested profile (comfort, eco, protection) in a given hour of the day (**Menu / Schedule settings**).

V.b) Temperature settings

The parameters in this submenu allow the user to adjust the set temperatures for the controller's particular profiles (see the previous chapter). The user may change the following temperatures:

- **Comfort temperature** - changing (editing) the room's set temperature in the profile Comfort.
- **ECO min temperature** - changing (editing) the room's minimum set temperature in the profile ECO.
- **ECO max temperature** - changing (editing) the room's maximum set temperature in the profile ECO.
- **Protection min temperature** - changing (editing) the room's minimum set temperature in the profile PROTECTION.
- **Protection max temperature** - changing (editing) the room's maximum set temperature in the profile PROTECTION.



V.c) Time settings

After the user presses the Time icon in the main menu, a screen allowing the user to change the timer settings, the current date as well as to determine the time frames for day and night appears.

- **Day from / Night from**

This option allows the user to change the hours in which the controller switches to the night mode (Night from) as well as will return to the day mode (Day from).

- **Timer settings**

This function allows the user to change the currently displayed time.

- **Date settings**

This function allows the user to change the currently displayed date.



V.d) Schedule settings

The parameters in this submenu are used for programming particular schedules.

After the user selects the schedule the settings of which the user wishes to edit, the display will show the following settings screen. Using the icons ◀ or ▶ the user changes the time interval (settings with accuracy to one hour). The icons ▲ and ▼ allow the user to change the profile assigned to a given hour. If the user wishes to copy a setting to neighboring hours, the user should just press the icon ● and then the icon ◀ or ▶.



V.e) Screen settings

- **Screen brightness during the day / screen brightness during the night**

After the user presses the icon, the user may adjust the percentage value of screen brightness during the day and during the night.



V.f) Alarm clock settings

In this function, the user adjusts the alarm clock. It is possible for the alarm clock to be activated only on selected days of the week (active on selected days) or to be activated once.



- The user adjusts the waking hour with the use of the "up" and "down" arrows.



- When the alarm clock is to be active only on selected days of the week, the user should mark the days on which the alarm clock is to be activated.



Controller screen view when the alarm clock is activated.

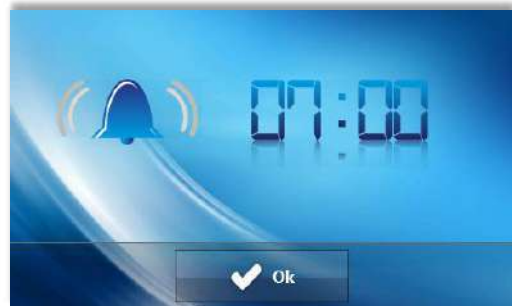

V.g) Controller settings

- **Room temperature sensor**

In this submenu, the user may calibrate the room temperature sensor.

The calibration is performed during the installation or after a longer period of using the regulator if the room temperature measured by the internal sensor differs from the actual temperature. Adjustment range: -10 to + 10°C with accuracy to 0.1°C.



- **Fan revolution settings**

This function allows the user to adjust the value of the fan's revolutions in the manual operation mode (see chapter Description of main screen) for particular speeds.



V.h) Protections

After the user presses the icon Protections in the main menu, a panel used for changing the parental lock settings appears. After the autolock is activated (the user marks the option Auto-lock enabled) changes of the controller's settings will be protected with a four-digit PIN code - after the screensaver is activated after a period of inactivity, it is not possible to browse the menu options without entering the code.

In order to adjust the PIN code necessary to operate the regulator (when the lock is active), the user should press the icon *Auto-lock PIN code*.



CAUTION

The factory set PIN code is "0000".

V.i) Language selection

After the user presses the icon Language selection in the main menu, a panel used for changing the language appears.



V.j) Information about software

After the user presses this icon, the display will show the manufacturer's logo along with the software version.

V.k) Stand-by mode

This function is used to activate the stand-by mode – the controller proceeds to the stand-by mode. It will not control the operation of the fans or valves. This is an energy-saving mode. The controller proceeds into its regular operation mode after the user touches the main panel.

V.1) Service settings

The service settings are used to adjust the advanced parameters of the controller's operation and should be operated by qualified persons. The detailed description of these parameters may be found in the next chapter. Access to parameters in the service menu is protected with a four-digit code.

VI. Controller functions – service menu options

The service menu should be operated by appropriately qualified persons and is used primarily for settings of the controller's additional functions such as set temperature of deltas, output configuration etc.

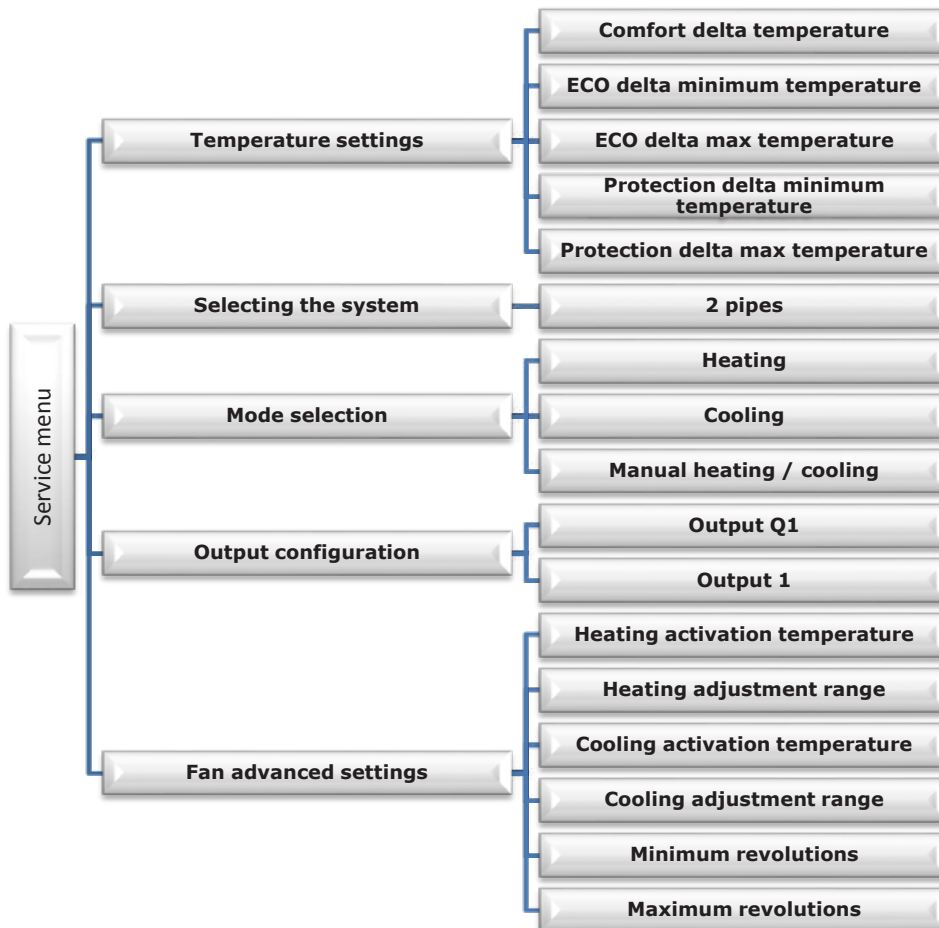

VI.a) Temperature settings

The parameters in this submenu are used to adjust the deltas temperature values for particular operation profiles. The delta value determines the moment in which the controller switches into smooth control over the valve and the fan – this is described in detail in the chapter Profile selection.

The delta parameters may be adjusted for each set temperature:

- **Comfort delta temperature** - applies to the profile Comfort.
- **ECO delta minimum temperature** - applies to the profile ECO, the minimum set temperature
- **ECO delta max temperature** - applies to the profile ECO, the maximum set temperature
- **PROTECTION delta minimum temperature** - applies to the profile PROTECTION, the minimum set temperature
- **PROTECTION delta max temperature** - applies to the profile PROTECTION, the maximum set temperature



VI.b) Selecting the system

This option is used to select the type of system for which the controller is intended.



VI.c) Selecting the mode

The parameters in this submenu are used to determine the controller's valid operation mode:



- **Heating** - no possibility to switch to Cooling mode from the level of the main screen. The user marks this option if the system is planned for heating.
- **Cooling** - no possibility to switch to Heating mode from the level of the main screen. The user marks this option if the system is planned for cooling.

If the user selects the Heating or Cooling function, the icon for changing the operation mode disappears from the controller's main screen. An icon signaling which mode is valid is displayed in the right-hand top corner instead, this may be seen on screenshot below – the valid mode in this case is Cooling.

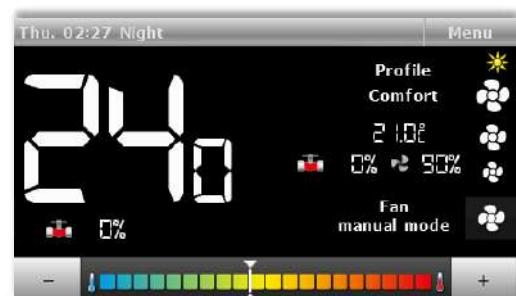

- **Manual heating / cooling** - the user may change the operation mode from the level of the main screen – by pressing the icon for changing the operation mode

VI.d) Output configuration

The parameters in this submenu are used to configure the operation of outputs:



- **Output Q1**

These settings apply to the operation of the valve controlled with the use of the output ON/OFF.



The user determines the valve's role in the submenu **Type of output:**

- **Heating** – after the user marks this option, the valve controlled from the output ON/OFF will operate in the heating mode.
- **Cooling** – after the user marks this option, the valve controlled from the output ON/OFF will operate in the cooling mode
- **Disabled** – after the user marks this option, the valve's operation will be disabled.



Additionally, the user may change the settings of the following parameters:

- **Heating hysteresis** - This option is used to adjust the heating hysteresis used in the heating mode. This is the difference between the set temperature and the temperature of return to operation for example: when the set temperature has the value of 20°C and the hysteresis is 2°C. After the set temperature is reached, namely 20°C, the valve is closed. The valve will open again after the temperature decreases to 18°C.
- **Cooling hysteresis** - This option is used to adjust the cooling hysteresis used in the cooling mode. This is the difference between the set temperature and the temperature of return to operation. for example: when the set temperature has the value of 22°C and the hysteresis is 2°C. After the set temperature is reached, namely 22°C, the valve is closed. The valve will open again after the temperature increases to 24°C

- **Output 1**

These settings apply to the operation of the valve controlled with the signal 0-10V:

- **Heating** – after the user marks this option, the valve controlled with the signal 0-10V will operate in the heating mode.
- **Cooling** – after the user marks this option, the valve controlled with the signal 0-10V will operate in the cooling mode
- **Disabled** – after the user marks this option, the valve's operation will be disabled.

VI.e) Fan advanced settings

The parameters in this submenu are used to adjust the fan's operation.

- **Heating activation temperature**

This parameter determines the shift downwards in the scope of the fan's adjustment as compared to set temperature in the heating mode.

- **Heating adjustment range**

The parameter determines the width of the range of temperatures in which the controller is to smoothly change the fan's revolutions in the heating mode.



Example:

The scheme below presents the operation of the valve and the fan with the following settings:

Set temperature: 20°C

Comfort delta temperature: 1°C

Heating activation temperature: 0.5°C

Heating adjustment range: 2°C

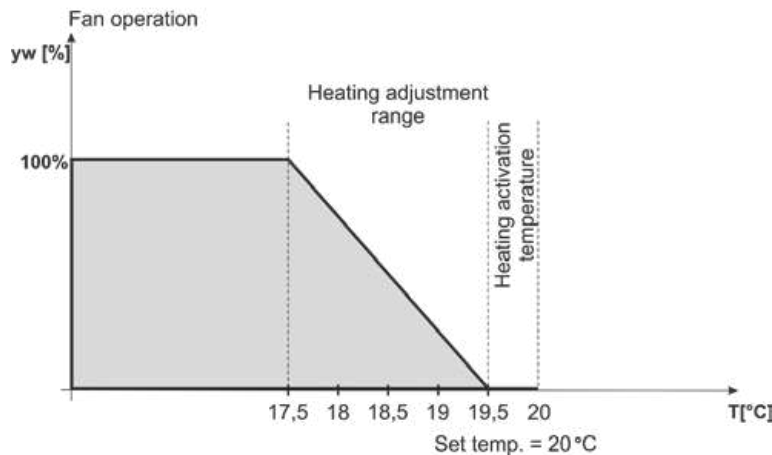
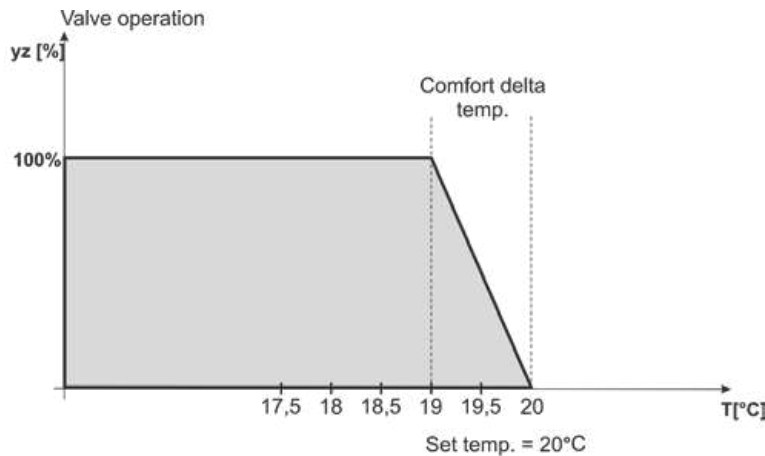

With the settings above, the valve will be open until the temperature 19°C is reached in the room ($T_{zad} - \text{delta comfort}$). After this value is reached, the valve will gradually begin to close. When the set temperature is reached in the room, the valve will close completely.

The fan will operate with full speed until the temperature 17.5°C in the room is reached ($T_{zad} - \text{Heating activation temperature} - \text{Heating adjustment range}$) – after this value is reached, the fan will gradually begin to reduce the revolutions until it is completely disabled when the temperature 19.5°C is reached

(Tzad – Heating activation temperature).

- **Cooling activation temperature**

This parameter determines the shift upwards in the scope of the fan's adjustment as compared to the set temperature in the cooling mode.

- **Cooling adjustment range**

This parameter determines the width of the range of temperatures in which the controller is to smoothly change the fan's revolutions in the cooling mode.

- **Minimum revolutions**

This parameter allows the user to determine the fan's minimum revolutions.

Calibration procedure for minimum revolutions:

The user enables the function Minimum revolutions in the controller. The user gradually increases the settings in the controller until the moment when the user sees that the fan begins to revolve. The user accepts the selection with the OK button.



- **Maximum revolutions**

This parameter allows the user to determine the fan's maximum revolutions.

Calibration procedure for maximum revolutions:

The user enables the function Maximum revolutions in the controller. The user gradually increases the settings in the controller – the fan accelerates to maximum revolutions. When the user sees that the fan does not accelerate despite the increased settings, the user accepts the settings with the OK button.

VII. Alarms

The VER-24 room temperature regulator will signal all alarms that occur in the controller. When an alarm is activated, the room regulator will send an acoustic signal and the display will show an appropriate message. When an alarm occurs, the controller disconnects the outputs. When the internal sensor is damaged, the alarm "Room temperature sensor damaged" will appear.



Technical data

Room temperature settings range	5°C - 40°C
Power supply voltage	24V
Power consumption	1.3W
Room temperature measurement error	+/-0.1°C
Operation temperature	5°C - 50°C

Declaration of conformity no 169/2015

The company TECH, based in Wieprz 1047A, 34-122 Wieprz, declares with complete liability that our temperature regulator VER-24 meets the requirements of the Act dated April 13, 2007 on electromagnetic compatibility (Journal of Laws 07.82.556) implementing the provisions of Directive **(EMC) 2004/108/EC**, and the Regulation of the Minister of Economy dated May 8, 2013 "on basic requirements on the restriction of the use of certain hazardous substances in electrical and electronic equipment" implementing the provisions of Directive **ROHS 2011/65/EC**.

Harmonized standards were used to assess the conformity **PN- EN 60730-2-9:2011, PN-EN 60730-1:2012**.

The product was marked with **CE**: 06-2015



PAWEŁ JURA **JANUSZ MASTER**
WŁAŚCICIELE TECH SP. J.

Wieprz, June 16, 2015



Dbalność o środowisko naturalne jest dla nas sprawą nadrzędną.

Świadomość, że produkujemy urządzenia elektroniczne zobowiązuje nas do bezpiecznej dla natury utylizacji zużytych elementów i urządzeń elektronicznych.

Symbol przekreślonego kosza na śmieci na produkcie oznacza, że produktu nie wolno wyrzucać do zwykłych pojemników na odpady.

Segregując odpady przeznaczone do recyklingu pomagamy chronić środowisko naturalne.

Obowiązkiem użytkownika jest przekazanie zużytego sprzętu do wyznaczonego punktu zbiórki w celu recyklingu odpadów powstałych ze sprzętu elektrycznego i elektronicznego.

Care for the natural environment is our priority.

Being aware of the fact that we manufacture electronic devices obligates us to dispose of used elements and electronic equipment in a manner which is safe for nature.

The symbol of a crossed out rubbish bin on a product means that the product must not be thrown out to ordinary waste bins.

By segregating waste intended for recycling, we help protect the natural environment.

It is the user's responsibility to transfer waste electrical and electronic equipment to a selected collection point for recycling of waste generated from electronic and electrical equipment.

Manual valid from June 1, 2015

After the editing of this manual was completed on June 1, 2015, changes in products specified in the manual could have taken place. The manufacturer reserves the right to change the structure or change the determined colors. The illustrations may contain additional equipment. The printing technology may affect differences in shown colors. Current information will be provided by dealers of Verano-konwektor products.

Terms and Conditions

You must immediately remove all packaging, inspect the goods and notify us of any damage to the goods within 3 days of delivery. We shall have no obligation to replace or repair damaged goods in the event of failure by the Buyer to comply with this provision. Radiators which are off an unacceptable standard or are damaged must not be installed. If any items is installed it will be treated as being as accepted as received.

Damaged goods being returned will only be collected from your delivery address, unless otherwise agreed in writing. Any other goods, which we accept back, are to be returned by you to our place of business at your expense.

Items will be accepted as a return which have not been installed or damaged after delivery. We do not accept liability for any damages sustained after delivery. Goods should be returned in their original packaging, provided such packaging and goods are undamaged.

We may issue a credit note for goods which we accept as returned.

We may agree to provide you with replacement goods prior to collecting or receiving back the goods to be returned (whether faulty, damaged or otherwise) but only on the condition that: the replacement goods are paid for in full and we reserve the right to re-invoice you in the event that the returned goods are found to be in a worse condition than when they were originally received by you or where such goods have not been received back to us within 3 months of the replacement goods being received by yourselves. A re-stocking charge of 30% will be applied to all non-faulty stock items that wish to be returned. Special order and non-stock products cannot be cancelled. Where cancellation or alteration of orders is accepted by us, you may be required to pay a restocking charge, to cover administrative costs and collection costs (if applicable); such charges to be determined by us. If the goods we deliver are faulty or damaged, we will meet the cost of the return, as long as the fault is reported to us within 3 working days.

The goods will be deemed to have been accepted when they have been delivered and we may not accept claims for any visible defects found after installation.

We accept no liability for any cost incurred relating to the cost of installation.

We shall not be liable for any plumber's costs, decorator's costs, transport costs, late penalties, or any other costs, as a direct or indirect result of (i) any defect in the goods (including but not limited to any manufacturing faults, such as leaks, that become apparent on or after installation) or (ii) late delivery of the goods.

GUARANTEES AND LIABILITIES – we are not the manufacturer of this product we will take all reasonable endeavours to make over to you the benefit of any warranty or guarantee given by the manufacturers. The item must have been fitted in accordance with British and or European standards as well as these fitting instructions.

